

Novinky pro rok 2021/2022

**CynkoMet<sup>®</sup>**



# Přepravník balíků T-608/3 – tříosý

Nyní lze zamontovat kola 500/50-

17

**CynkoMet®**



# 608/2E – Prodloužená ložná plocha

na 8,2m

10T a 12T Nosnost!!!!

**CynkoMet®**

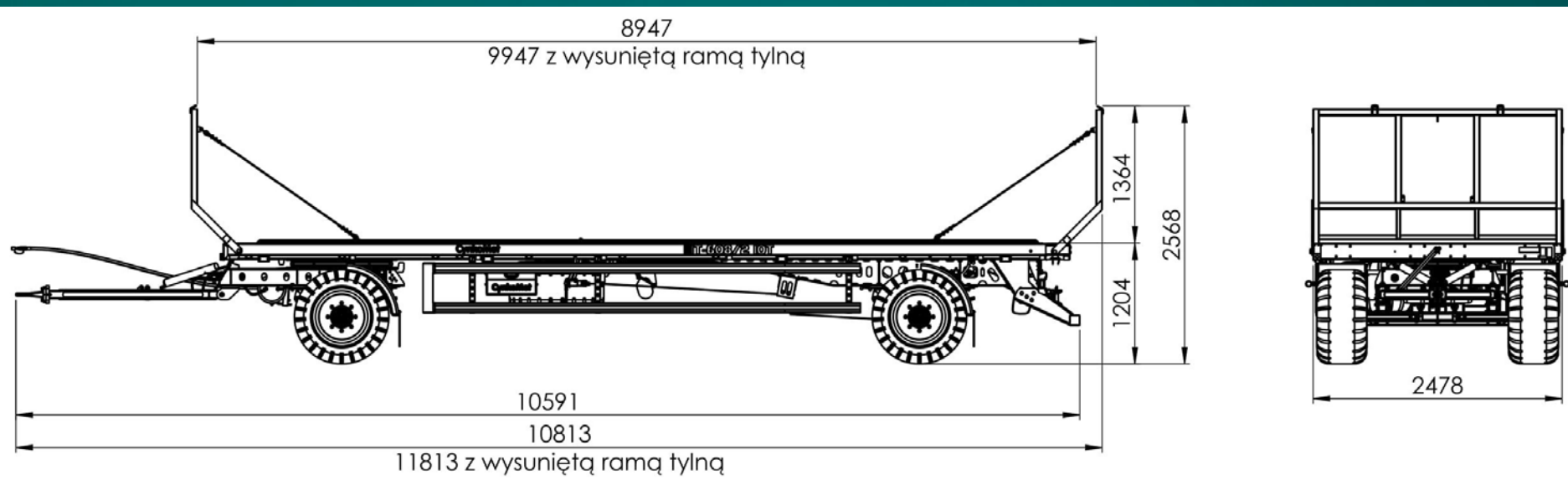

# Hydraulické bočnice pro T-608/2 (8,2m) a T-608/3

CynkoMet®

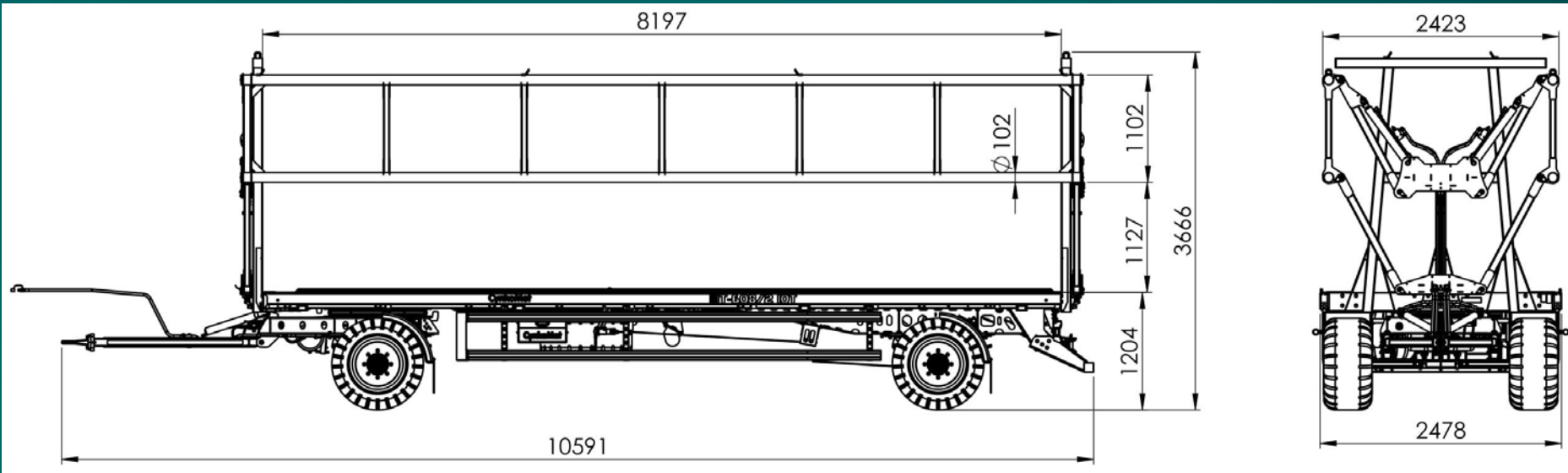

# Hydraulické bočnice pro přepravníky T-608/2 (8,2m) a T- 608/3



T-617/4 – řiditelná náprava)

max. 22T (18T na nápravách, 4T oko K80)

Nosnost do 16,5T

CynkoMet®

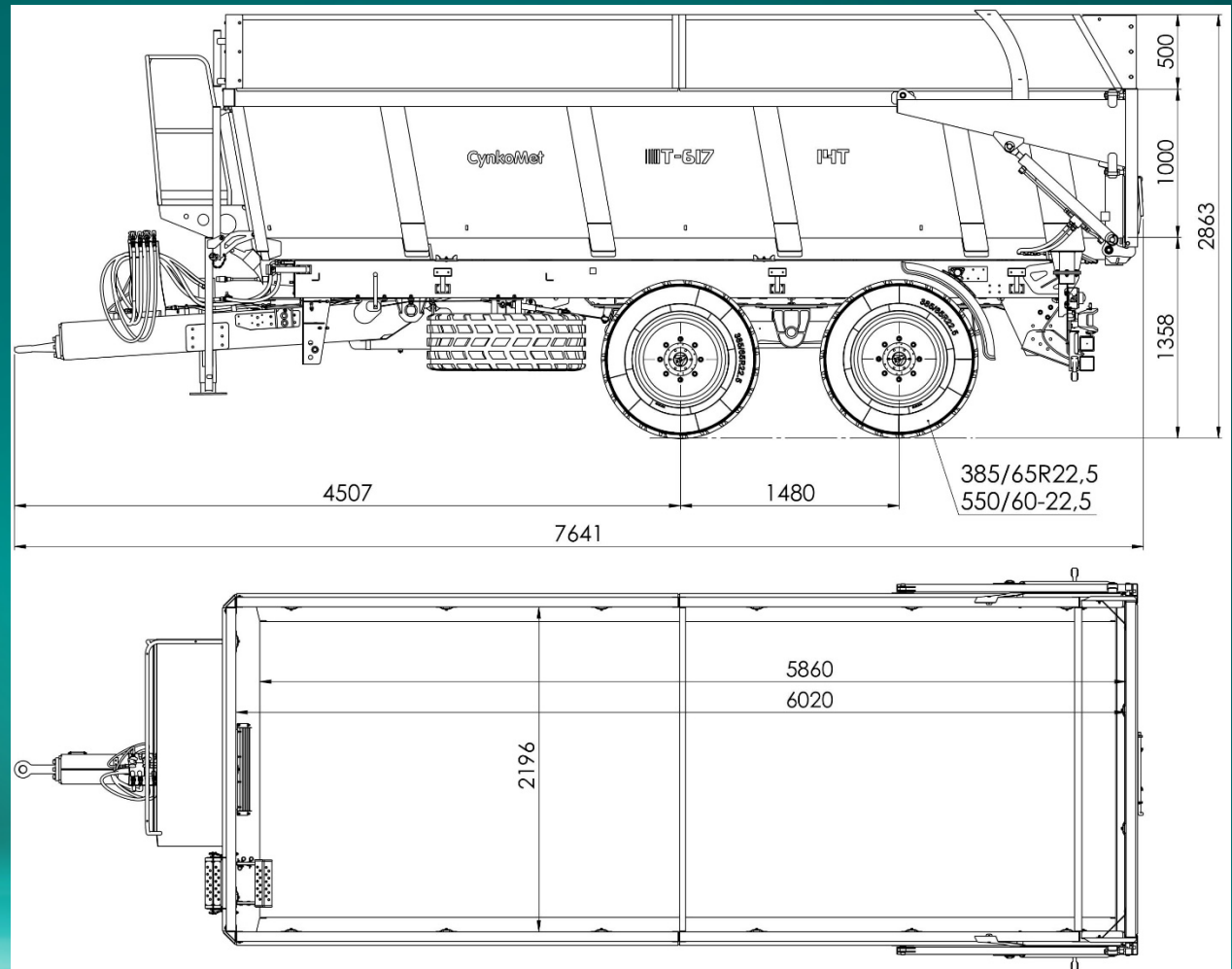

## Rozmetadlo chlěvské mrvy s nakládací rukou P1 i P2



## Rozmetadlo chlěvské mrvy s nakládací rukou





# Nový jednonápravový návěs návěs T-118 nosnost ~6T

CynkoMet®

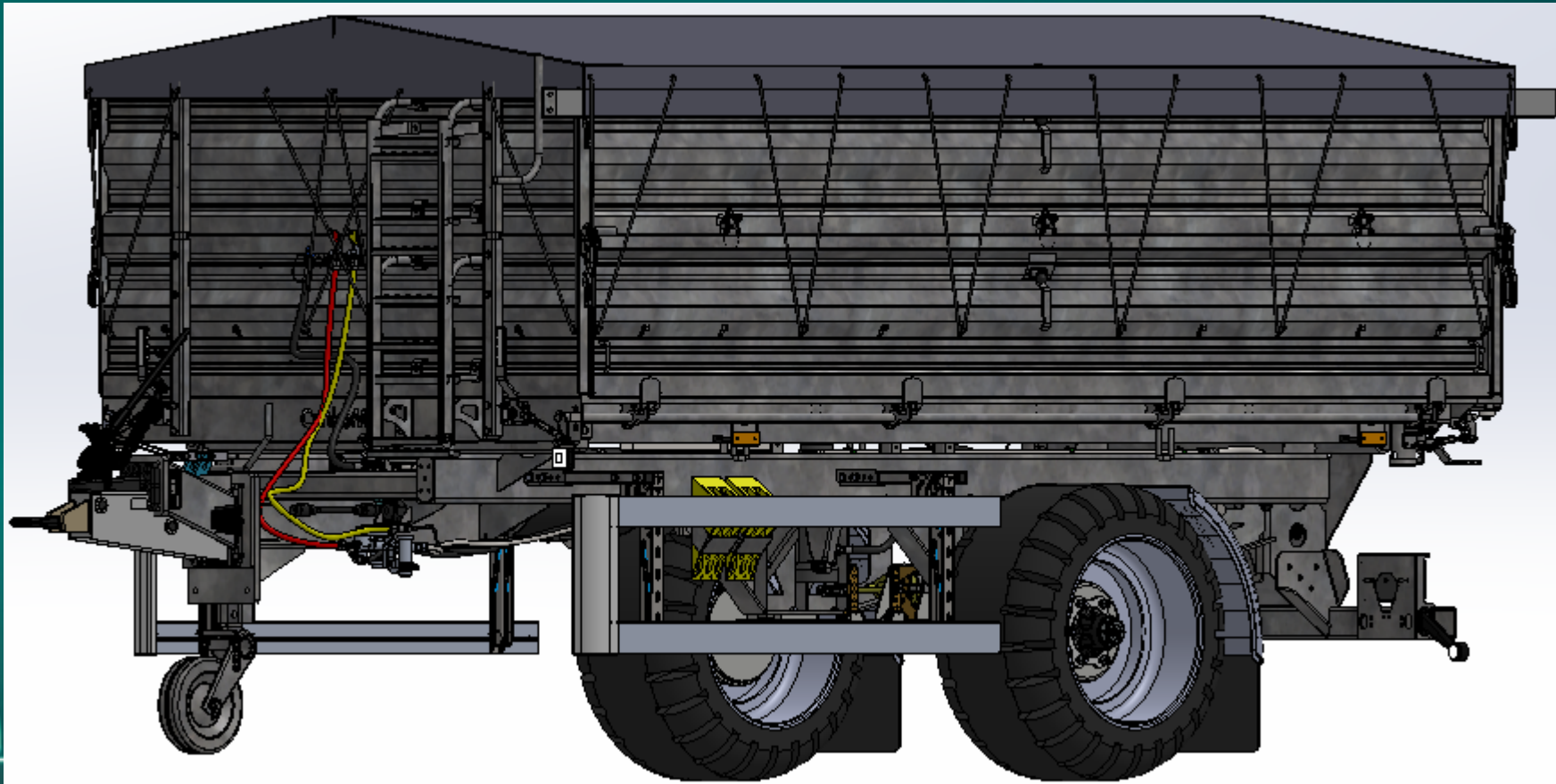

# T-118

# CynkoMet®

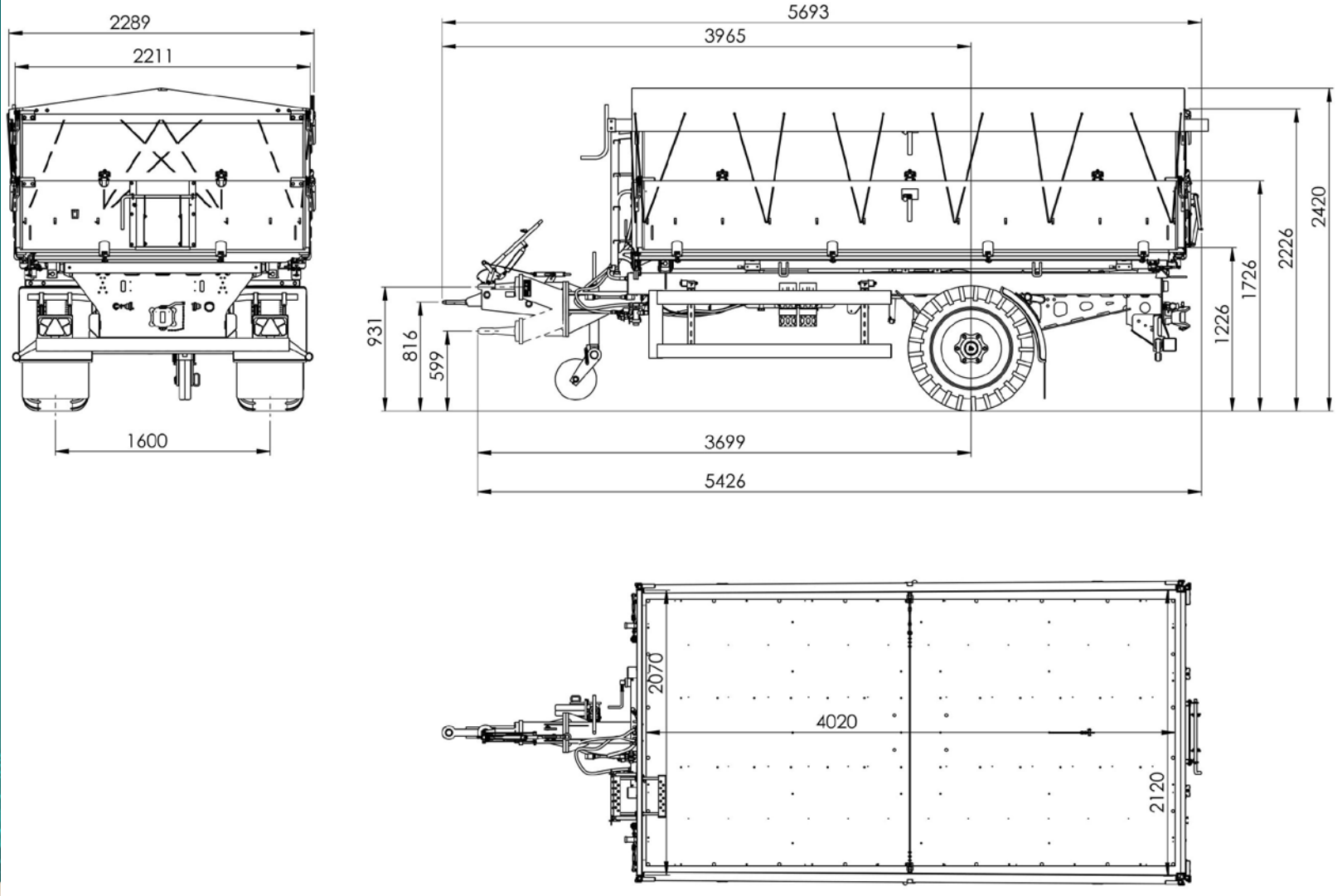

# Speciální návěs pro přepravu beden



## PW-22

konstrukční nosnost 16T (8 palet o rozměru 1,2x1,6)

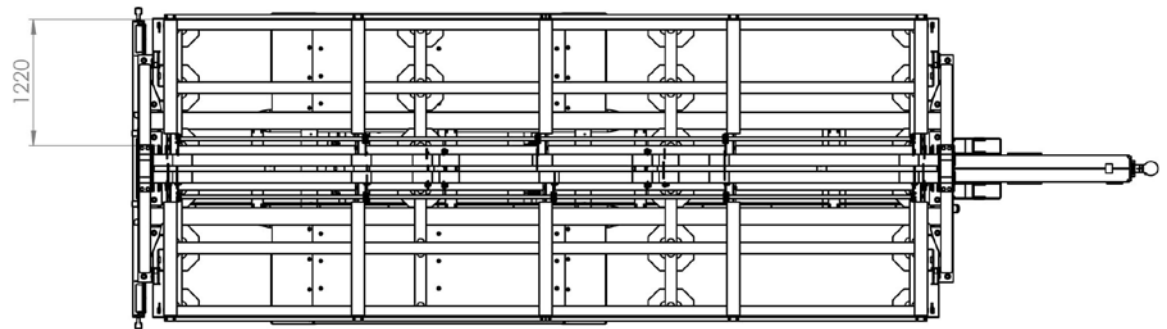
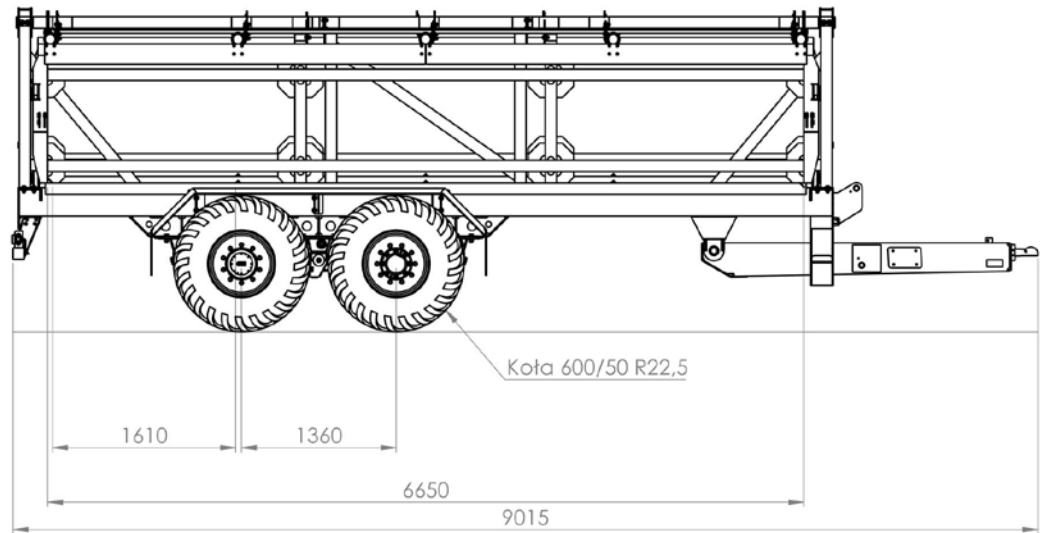
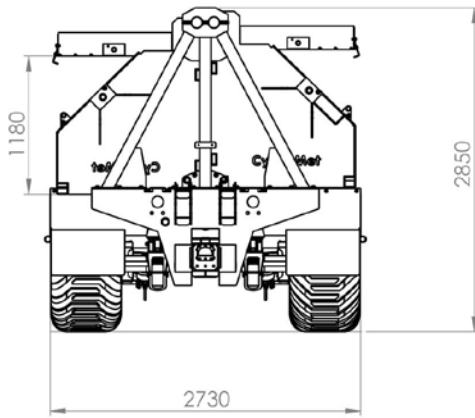

PW-22

CynkoMet®



PW-22

CynkoMet®



# Rozmetadlo chlěvské mrvy 6T a 8T

CynkoMet®

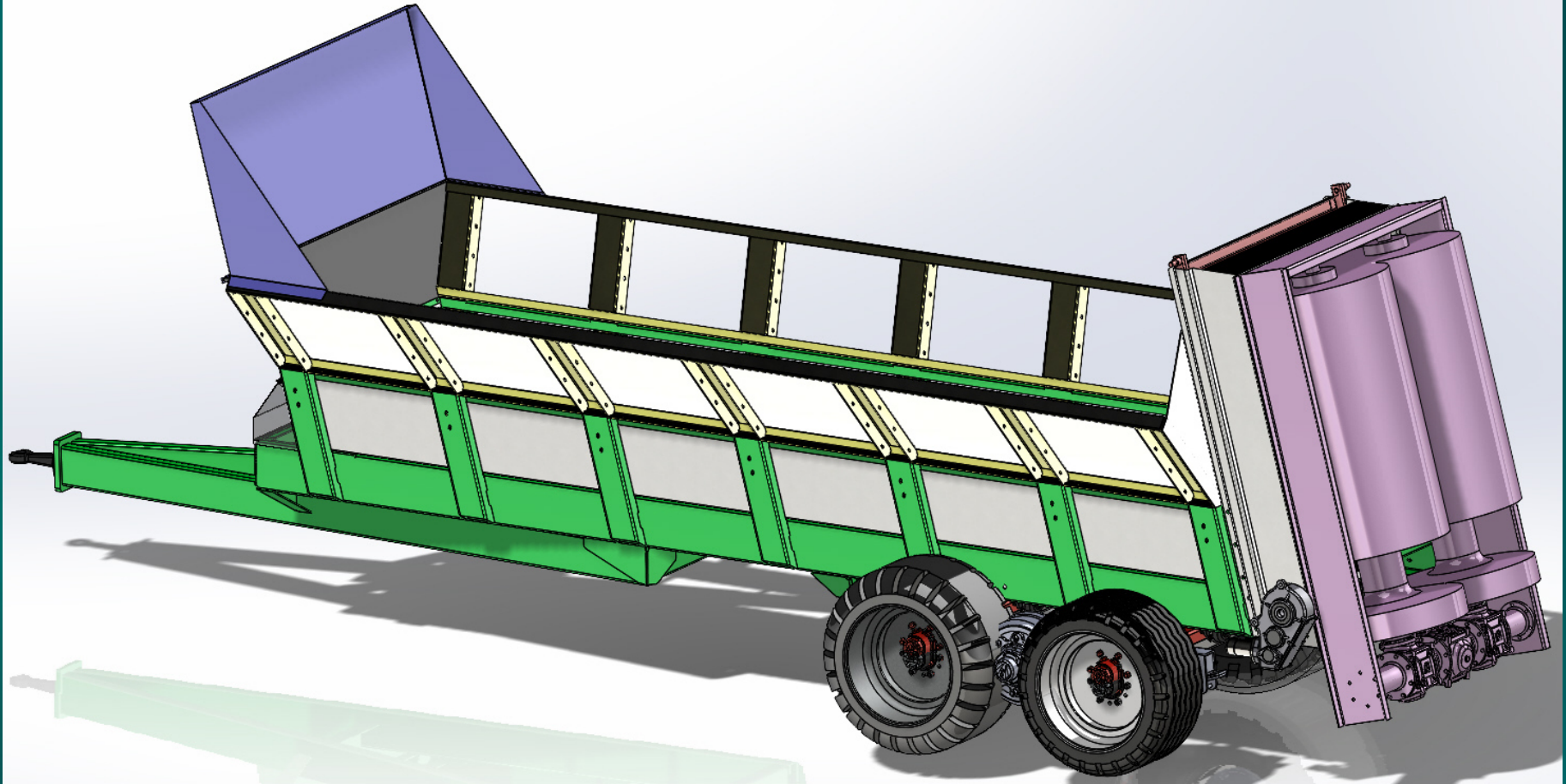

# Rozmetadlo chlěvské mrvy 6T a 8T

**CynkoMet®**

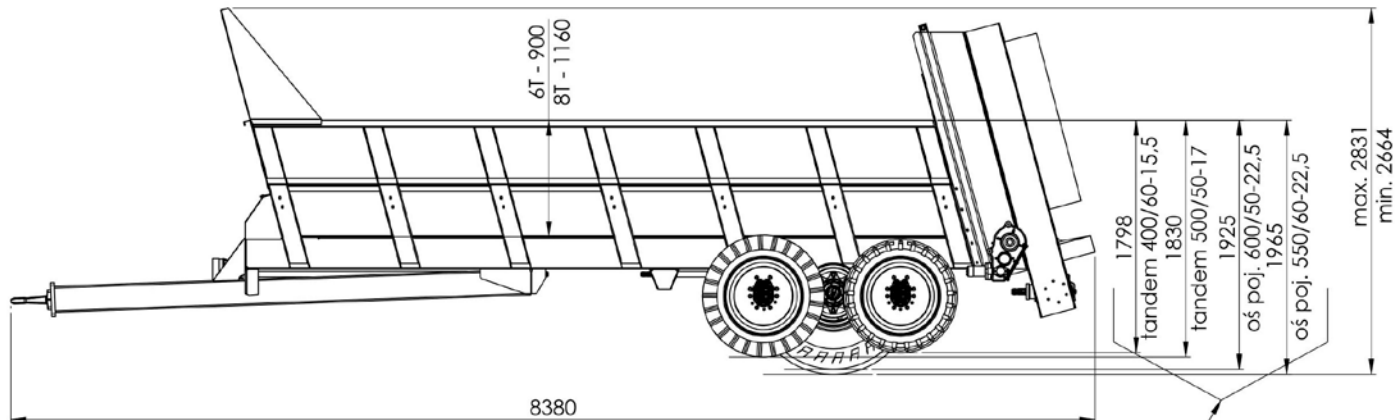
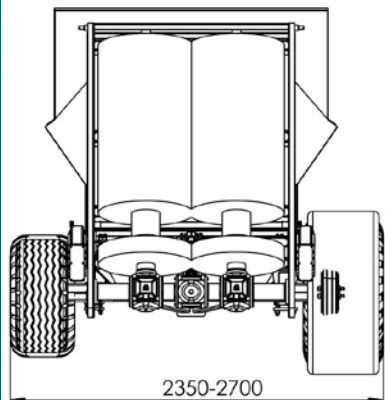

Wymiary rozrzutnika 6T  
8T + 260mm

Pojemność		
	na płasko	z usypem
6T	~7,8m <sup>3</sup>	~10,9m <sup>3</sup>
8T	~9,9m <sup>3</sup>	~13m <sup>3</sup>

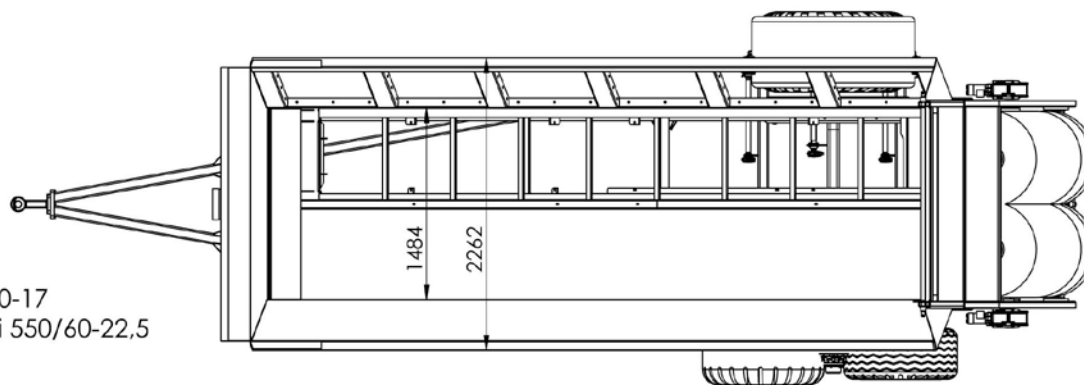

Opony:

Tandem: 400/60-15,5 i 500/50-17

Pojedyncza oś: 600/50-22,5 i 550/60-22,5

